

# A THERMOSTAT FOR EXAMINING LIGHT SCATTERING NEAR THE CRITICAL UNMIXING POINT FOR A SOLUTION

S. I. Balashova, D. K. Beridze,  
and V. S. Bronskvazer

UDC 536.58:535.32

A description is given of a thermostat convenient for optical measurements near the critical unmixing point.

This precision thermostat (Fig. 1) was designed to hold a temperature to  $\pm 0.0005^\circ\text{C}$  for several days for use in extinction measurements within  $0.001^\circ\text{C}$  or so of the critical unmixing point. It consists of three coaxial cylinders separated by asbestos insulation. The outer cylinder constitutes a water jacket whose temperature is set and maintained to  $\pm 0.15^\circ\text{C}$  by means of a Wobser thermostat. The two inner cylinders are thick-walled aluminum vessels (wall thickness  $\delta$  of outer one 20 mm, of inner one 30 mm). On the outer surface of each is a six-start screw thread used to mount the bridge and the heater, which are insulated from the body by bakelite varnish, which is applied in solution in acetone from a sprayer onto the cylinder rotating slowly in a lathe. The cylinder is then kept for several hours in a drying oven at about  $100^\circ\text{C}$ . This operation is repeated seven times to produce a thin, strong, and uniform layer of varnish. Two arms of the bridge are made of platinum (Pobeda grade  $d = 0.05$  mm) annealed at  $600^\circ\text{C}$ , while the other two arms are made of manganin ( $d = 0.1$  mm). One arm is adjustable for resistance by means of a parallel resistance box. Each cylinder is controlled independently by an analog circuit (Fig. 2). The bridge is balanced at a certain temperature for a given resistance in the adjustable arm. The dc sources (1.5 V for the inner cylinder, 3 V for the outer) consisted of Ekran batteries. The arms are denoted by  $R_1$ ,  $R_2$ ,  $R_3$ , and  $R_4$ ; the bridge is balanced if  $R_1/R_2 = R_4/R_3$ . The resistance of the platinum ( $R_1$  and  $R_3$ ) has a temperature coefficient  $\alpha = 0.0038 \text{ deg}^{-1}$ , while the resistance variation in the manganin ( $R_2$  and  $R_4$ ,  $\alpha = 0.000001 \text{ deg}^{-1}$ ) can be neglected.

If the cylinder cools, an unbalance signal appears in the bridge diagonal, which is recorded and amplified by an F 116/2 millivoltmeter system. The dc amplifier based on P101 and P201 transistors (Fig. 2) sends a signal to the heater (constantan,  $d = 0.18$  mm), which has a bifilar winding on the cylinder. The heater raises the cylinder temperature to the balance point. Similarly, an excess temperature produces a cut-off signal (no current in heater) and the cylinder cools. There must therefore be certain fixed temperature differences between the cylinders. In our case, that between the outer and inner cylinders was  $0.10 \pm 0.005^\circ\text{C}$ , while there was  $0.50 \pm 0.15^\circ\text{C}$  between the outer cylinder and the thermostatic block. The resistances in the inner bridge ( $\Omega$ ) at  $20^\circ\text{C}$  were  $R_1 = 439 \Omega$ ,  $R_2 = 375 \Omega$ ,  $R_3 = 444 \Omega$ ,  $R_4 = 383 \Omega$ , while the heater resistance was  $R_h \approx 80 \Omega$ . For the outer cylinder at  $20^\circ\text{C}$   $R_1 = 942 \Omega$ ,  $R_2 = 853 \Omega$ ,  $R_3 = 970 \Omega$ ,  $R_4 = 849 \Omega$ ,  $R_h \approx 160 \Omega$ . The adjustable resistance changed from about 1200 to 1400  $\Omega$  for the inner bridge in response to a change of about  $0.5^\circ\text{C}$ , or about 3400 to 4500  $\Omega$  for the outer one. The effects of room-temperature variation on the adjustable resistance were minimized by choosing the arm resistance so that the adjustable resistance was as large as possible.

The response to temperature change is governed primarily by the response of the F 116/2, which could detect  $10^{-9}$  A.

The aluminum is of high thermal conductivity and facilitates temperature equalization. The temperature difference between the cylinders was measured to  $\pm 0.05^\circ\text{C}$  by Chromel-Alumel couples. Longitudinal temperature differences of about  $2 \cdot 10^{-4}^\circ\text{C}$  were found within the inner cylinder. The entire system

---

M. V. Lomonosov State University, Moscow. Translated from *Inzhenerno-Fizicheskii Zhurnal*, Vol. 18, No. 2, pp. 343-346, February, 1970. Original article submitted April 17, 1969.

© 1972 Consultants Bureau, a division of Plenum Publishing Corporation, 227 West 17th Street, New York, N. Y. 10011. All rights reserved. This article cannot be reproduced for any purpose whatsoever without permission of the publisher. A copy of this article is available from the publisher for \$15.00.

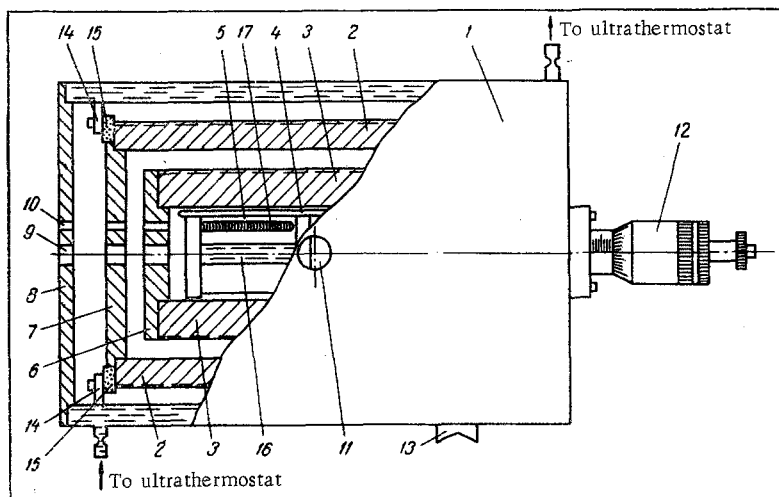

Fig. 1. General view and arrangement of thermostat: 1) thermo-  
stating jacket; 2) external cylinder; 3) internal cylinder; 4)  
moving platform; 5) cylinder with immersion; 6, 7, 8) lids of in-  
ternal cylinder, external cylinder and jacket, respectively; 9)  
window; 10) hole for leads; 11) holder for diffused light; 12)  
micrometer screw; 13) socket; 14) ring for external cylinder;  
15) tufnol; 16) tank with liquid; 17) resistance thermometer.

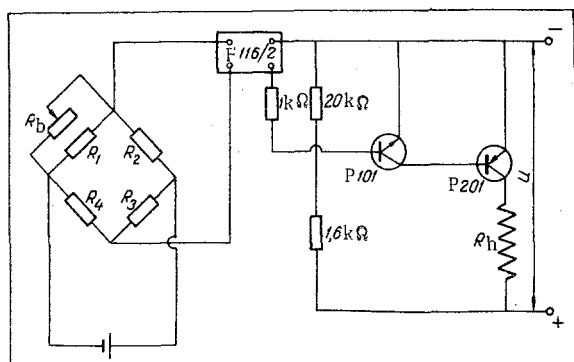

Fig. 2. Electric thermostatic circuit.

a moving device mounted within the thermostat on a tufnol rod. A special adjustable tufnol cell was used for the purpose.

The extinction coefficient was measured near the critical unmixing point, and equilibration was very slow, so it was necessary to stir the liquid in the cell without interfering with the adjustment of temperature control. The thermostat was placed on a support for this purpose, with one end bearing on a metal rod and the other held by a positioning device attached to the transverse plate, which could be moved aside after lifting this end. The thermostat could then perform rotational oscillations in a vertical plane, which provided the necessary stirring for the liquid in the cell.

The working temperature range is affected by: 1) the nature of the liquid entering the thermostatic jacket from the ultrathermostat; 2) the resistance ratio for the platinum and manganin arms; 3) the thermal stability of the insulation. The system can be used for other studies near the unmixing point (ultrasonic studies, measurement of dielectric constant, etc.).

#### LITERATURE CITED

1. D. K. Beridze and M. I. Shakhparonov, Ukr. Fiz. Zh., 7, 771 (1962).